

UNISORB POWER GENERATION ENGINEERED PRODUCTS

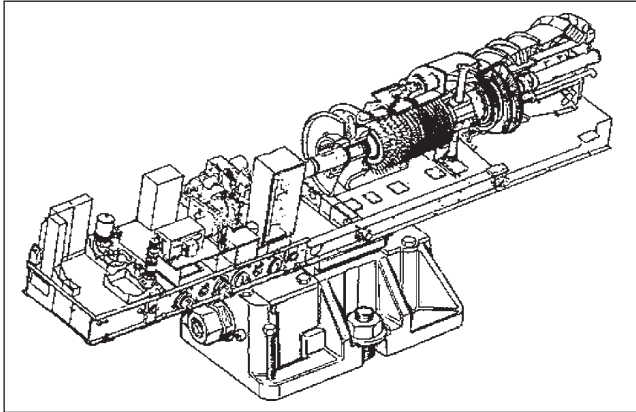

Since 1982 UNISORB Installation Technologies has been a supplier of anchoring/alignment systems, leveling devices and grouting materials for steam turbine installations. Our strong background in this field, coupled with our successful track record, positions us as a leader in the industry. Our experience pertinent to this field includes power generation, process and manufacturing.

UNISORB is the nation's leader in the manufacturing of premium quality machinery installation systems. Our factory trained field representatives are available during installation and system start-up to assure that maximum performance is attained.

UNISORB supplies equipment for power generation equipment mounting in kit form. These kits are designed and furnished for each specific machine application. They include all necessary hardware and support equipment for a complete and successful installation. A typical kit will contain grout pocket forms, grout products, foundation embedments, leveling devices, anchor bolts and setting plates, as well as specialized tools required for major, alignment critical installations.

Our grout pocket forms are unique, and make placing grout pockets simple. The form is simply slid over the anchor bolt and secured with the top of the form even with the top of the foundation. After the foundation is poured and stripped, the form is simply removed from the concrete by pulling up on the eye nuts supplied with it. Your grout pocket is now ready for use.



UNISORB Grout Pocket Forms are unique.

Each kit has its own set of engineering drawings to provide the field staff with all the necessary instructions and documentation to install a quality mounting system for the customers. Another feature of UNISORB's mounting systems is on site technical support. Our field engineers have what it takes to assist our customers with their machinery installation in a way that assures a *successful completion every time*.

The UNISORB Fixator System is utilized as the cornerstone of the mounting packages for steam turbine installations. This magnificent system is capable of aligning machinery to within .0001 of an inch, and in a far shorter time than was previously possible using other leveling devices. One of the key features of the Fixator is its capability of leveling the machinery after the anchor nut is tightened, using only a small hand wrench. (For more information on the Fixator see page 8 of this catalog.)

Needless to say, when you save time on installation you also save money. On some of the projects UNISORB power generation installation packages have been used on time *savings of up to 80%* have been achieved. This amounts to significant dollar savings by our customers.

UNISORB uses the latest manufacturing techniques available for manufacturing hardware contained in the kits. This helps to assure high quality products - on schedule. In addition, UNISORB stocks an extensive inventory of kits for specific power generation equipment for our customers.

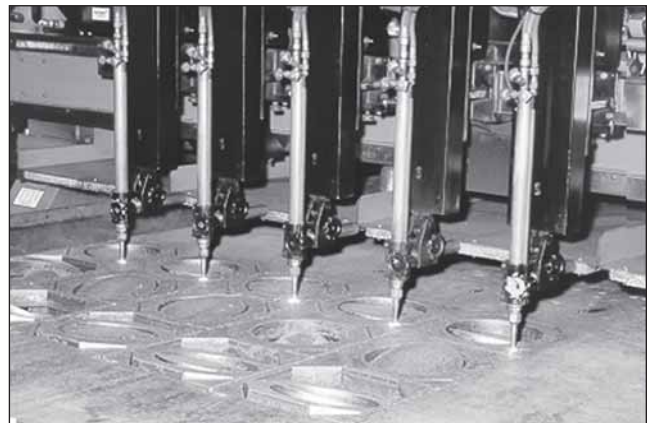

UNISORB uses latest manufacturing technology.



A large inventory of parts and kits are in stock.

UNISORB® POWER GENERATION ENGINEERED PRODUCTS

Proper packaging is an integral part of our policy to assure our customers will receive quality kits, with part identification. No expense is spared to supply the very best materials and workmanship on this phase of our business. UNISORB customers have been very pleased with our packaging procedures.



Packaging comes complete with part identification.



Only top quality goes into UNISORB packaging.

UNISORB has scores of satisfied customers who have taken advantage of our superior products and services over the years. Please consult with UNISORB's Power Generation Engineering Department for a list of these references.

For more information on UNISORB's power generation products call our engineers at 1-888-4-UNISORB.

PROJECTED COST SAVINGS UNISORB Systems vs. Conventional Methods

- **REDUCED LABOR** - Savings of 300 to 500 man hours on typical installations. Calendar savings of 9-14 days.
- **REDUCED PROJECT MANAGEMENT LABOR** - Fewer people are required on job sites; Fewer supervisory hours are required; Less personnel management required; Instructions and on site technical support provided by UNISORB.
- **REDUCED ORDERING AND QUOTING REQUIREMENTS** - One source for all material requirements; Multiple source and component quotes are eliminated; UNISORB supplies materials to customer specifications.
- **REDUCED DESIGN TIME** - All embedments and grout pockets are designed; Foundation layout and component drawings are furnished and can be referenced on construction drawings.
- **REDUCED REWORK** - Increased ability to deal with out of spec foundation and site preparation work; Costly rework and associated delays are minimized.

TYPICAL UNISORB KIT



Ready To Ship To Your Job