

Rapid Air Corporation Operating Instructions

**Keypad w/ Display
PMD Horizontal**

OPERATING INSTRUCTIONS PMD HORIZONTAL

(Revision)

10/1/2002

Warning!!!

Taut Stock (over travel reset) not connected.

Check wiring schematic to connect interface with material pulling device.

INSTALLATION

1. The machine that you have just received is fully assembled and ready to be put into position. Due to shipment vibration the machine should be checked to be sure all screws and bolts are tight and that all electrical components are in place inside cabinet. Visually inspect the machine for damaged parts due to shipment. If the machine was damaged in shipment, contact the carrier first to report the damage, and then Rapid-Air.
2. Install the machine on a level surface with sufficient clearance for loading and unloading coils.
3. The machine is completely self-contained and need only be plugged into a 20 amp, 120 volt, 60 HZ outlet. If an extension cord is used as the source to the machine, it should be a minimum #12 gauge wire to keep the voltage loss down and for electrical safety reasons.

See Drawing Below

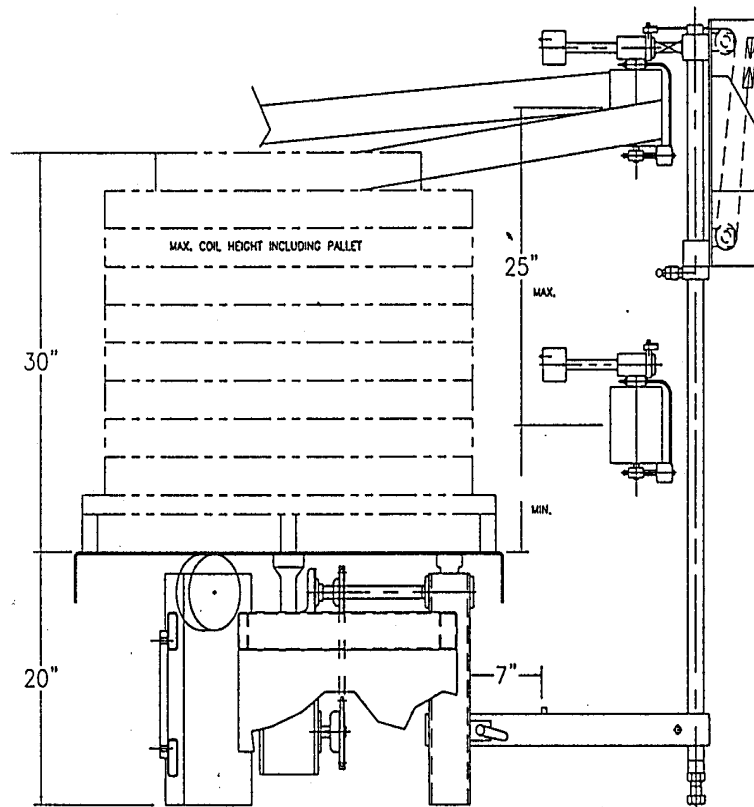

The main control unit is located behind the pushbutton cover. Below is an illustration of the layout of the control panel. This diagram lists all the components and the approximate location of each that could be used for troubleshooting the machine if a problem should occur. The reel is shipped with—120 VAC (1 phase) input. Visually check all electrics before starting the reel.

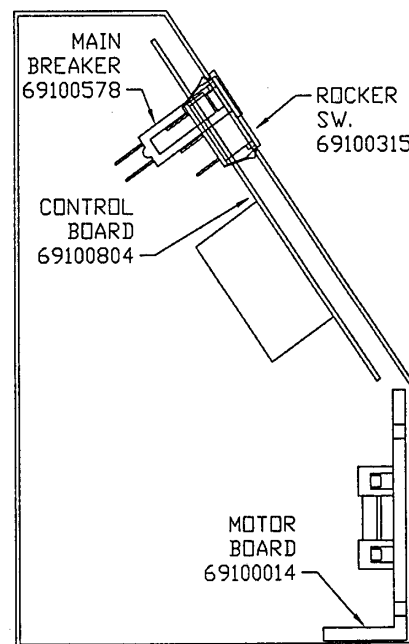
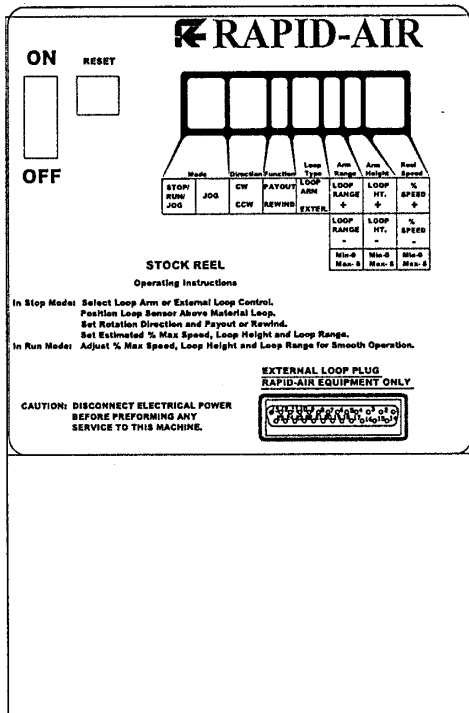

Mechanical Operating Procedure

To Load or Unload a Coil Ring

The PMD can handle any coils that are on a pallet, table diameter is 42 inches for the PMD-35 and 51 inches for the PMD-50 and max 3500 lbs on a PMD-35 and MAX 5000 lbs on a PMD 50, but only up to 30 inches in height from the table top.

Step 1:

Decide if the material that is paying out will go over the table or beside the table and which side of the table. If all the coils are wrapped the same way then choose a side that will be in line with the press and don't forget the ease of loading of the pallets. If the coils are wrapped so the table direction has to be switched to unwind the next coil then over the top will be best otherwise the PMD will have to be moved to pay off the other side as the material flow is the opposite way.

Step 2:

Make sure the arm is clear of the loading zone and load the pallet onto the table. Align the pallet so it is in the center of the table. Adjust the dancer arm roller assembly so that it is even with or slightly above the coil that is being unwound. Jog the table around so the end is within reach from the operator station and stop. Cut the material free and grab the loose end and then jog the table around so the material can be threaded in behind the roller. When there is sufficient material available, the PMD can be put into "run" and as the material is walked to the material work station the PMD will rotate and keep up.

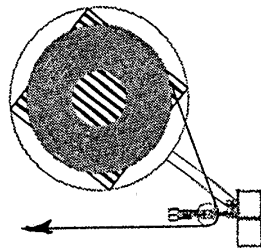

**CW ROTATION
PAYING OFF LEFT SIDE**

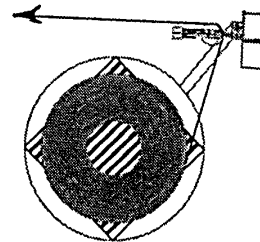

**CCW ROTATION
PAYING OFF RIGHT SIDE**

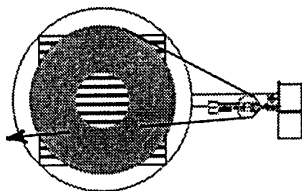

**CW ROTATION
PAYING OFF CENTER**

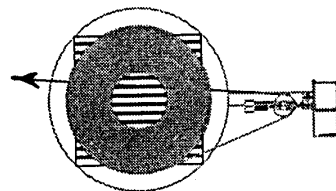

**CCW ROTATION
PAYING OFF CENTER**

Setting up the control

Turn on the main power switch and select “LH” for loop arm horizontal at “Loop Type” on the pushbuttons.

Turn off the main power switch, press and hold the “Run/Stop/Jog” button while turning the main power switch on. The first screen you see will display the jog speed percentage.

JOG SPEED	23% +
NEXT	-

If you want the jog speed faster then press the “Reel Speed “+ “ “ pushbutton. If you want the jog speed slower then press the “ Reel Speed “-” “ pushbutton. The jog speed is shown in percent of max jog speed. If the jog speed is “OK “ then push the Run/Stop/Jog button once for next.

The next screen asks if you want to set up the sensor? As before the percent speed buttons are used for the yes-no. Select “yes”! And then next.

SETUP SENSOR	YES
NEXT	NO

The next screen asks you to set the low set point. If the dancer arm is at “No Material Rest” then just save the setting by pushing the Stop/Run Jog pushbutton.

SENSOR LOW SETPOINT	
SAVE	XXX

The next screen is to set the offset of the program. Potentiometers are hard to get set from left to right so we built in an offset. If you set the low and high range and go into run and the reel runs for no reason then an offset has to be put in. Go through the setup procedure again and put in an offset of –3 to –5 and now the pot is zero.

LOW OFFSET	+0	+
NEXT		-

You have now set the dancer arm limits.
The next screen is to exit the setup and start working.

EXIT SETUP?	YES
	NO

Choose yes and next and the next screen appears.

SHUT OFF POWER TO SAVE AND EXIT

The dancer arm is now ready for production running.

DANCER ARM LOOP POSITION ADJUSTMENT

Eight different loop sensing arm operating positions can be selected during set-up. The material thickness determines the dancer arm rest position. Once the material is threaded up and the material is resting on the dancer arm and the reel runs in the rest position then select a higher number on the height adjustment until the reel stops rotating. The zero point of the dancer arm is moved from its no material rest position to the current rest position shown (as indicated 0-8). The dancer arm will start the material dereeling from the new rest position selected. The function is active and can be changed in the run mode.

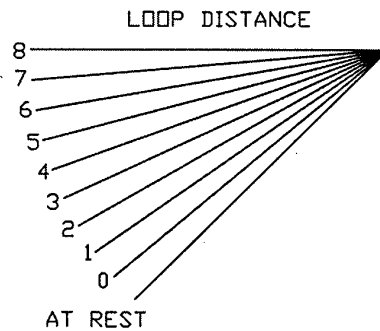

EACH NUMBER IS THE DISTANCE FROM REST THAT THE DANCER ARM HAS TO MOVE TO ACTIVATE THE REEL MOTOR.

DANCER ARM LOOP RANGE FUNCTION

The loop range function selects the degree of arm movement to achieve maximum motor speed selected. If a loop range of "0" was selected then the arm would only have to move approximately 1/2 inch to have the reel at full speed whereas if the loop range "8" was selected then the arm would have to move almost the full travel or approximately 41/2 inches to get to full speed. The function is active and can be changed in the run mode.

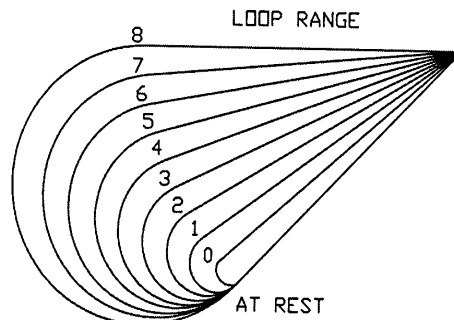

EACH NUMBER IS THE DISTANCE FROM REST THAT THE DANCER ARM HAS TO MOVE TO ACHIEVE FULL SPEED OF THE REEL MOTOR.

START UP PROCEDURE

Prior to applying power to the machine the operator should review all the controls on the machine. A brief summary of the controls is listed below.

MAIN CONSOLE & CONTROLLER

The main pushbutton control box is mounted next to the dancer arm pot on the control arm assembly. Located on the face of the console are eleven pushbuttons, one display, one on/off switch, one circuit breaker, one external loop plug and inside the box is motor board and one potentiometer when required, all of which are explained below.

1. DIRECTIONAL CONTROL - (CW/CCW) -

The direction control function selects the direction the reel will turn, clockwise or counter-clockwise. To find which way it should be programmed, Look at how the coil is wound and decide which way the coil should unwind, clockwise or counter-clockwise. Push the appropriate button until the correct rotation is displayed on the display. CW= clockwise & CCW= counter-clockwise.

2. % SPEED POT - The % speed function adjusts the maximum speed that the reel will rotate and should be set to maintain a constant feed rate. Adjustable in the run mode.

3. ON/OFF SWITCH - This illuminated switch is the main power switch for the controller. It must be "ON" for the machine to function.

4. PAYOUT/REWIND - The payout/rewind function selects whether the dancer arm will cause the reel to function at a low speed at the home position and increase the reel speed as the arm extends (Payout); or cause the reel to function at a low speed at the extended position and increase the reel speed as the arm retracts. (Rewind).

5. RUN/STOP/JOG - This function selects between Run, Stop & Jog. If in Run and the control arm is moved the coil plate will turn. If in Jog, the Jog button has to be depressed for the coil plate to turn. If in Stop, There should be no movement of the coil plate even if the dancer arm is raised or lowered or the jog pushbutton is pressed.

6. JOG BUTTON - Used for intermittent movement of material on the coil plate, mainly for set up or rewinding excess material. Active in jog mode only.

7. DANCER ARM LOOP HEIGHT & RANGE ADJUSTMENT -

a. Loop Range - The loop range function adjusts the amount the dancer arm will travel to provide the full range of speed of the reel. There are eight positions available.

b. Loop Height - The loop height function is used for setting the start position of the control arm. The setting determines when the reel will start turning. Each position will move the operating start position up from the home position to accommodate specific material rest position requirements.

8. LOOP ARM/EXTERNAL SWITCH

This switch selects either dancer arm (internal) by displaying "LV" for loop arm vertical reel or "LH" for loop arm horizontal reel (PMD) or external loop control by displaying "RT" for the RTB and "RS" for the RS_1. The RLL will work on the "RT" selection.

The external connection for a remote loop control on the PMDH usually isn't used as there is not much of a loop to look at for adjusting the motor speed.

9. RESET BUTTONS

- A. 15 amp - This is the main circuit breaker for the reel.

10. REMOTE INTERFACE PORT "D" CONNECTOR

This connector is used to communicate with external loop control equipment if used.

CAUTION: Never plug any type of computer or non Rapid-Air equipment into this plug or severe damage will result. Always consult with the factory when installing new external controls for compatibility and wiring information.

ELECTRICAL COMPONENT DESCRIPTION

69100804 board - main reel control board

69100014 (RAMM) - D.C. motor board

69100218 dancer arm potentiometer

69100578 circuit breaker

69100315 rocker switch

PMDH SPECIFICATIONS AND MAINTENANCE

CAPACITY

SERIES	35	50
COIL CAPACITY	3500 LBS	5000 LBS
STANDARD STOCK WIDTH	4"	6"
MAX MATERIAL THICKNESS	.062	.062
TABLE O.D.	42"	51"
MAX COIL OD	36"	50"
MAX SPEED	33 RPM	20 RPM
MAX COIL HEIGHT	30"	30"

ELECTRIC MOTORS

PMDH 35 IS furnished with 3/4 hp, 2500 rpm permanent magnet D.C. motor.

PMDH 50 IS furnished with 1 hp, 2500 rpm permanent magnet D.C. motor.

All motors are 90 V.D.C. unless otherwise specified.

All brushes on the motors should be checked every 1500 to 2000 hours.

LUBRICATION

Gear transmission oil - Use Mobil 600W cylinder oil or equivalent. Fill to bottom edge of the oil fill hole. The oil capacity of the gear box is as follows:

PMDH 35 32 oz.

PMDH 50 32 oz.

The oil should be changed every 1000 hours.

TROUBLE SHOOTING GUIDE

MAIN SWITCH ON BUT NOT LIT

1. CB tripped
 - a. Reset CB
2. Unit not plugged into main power.
 - a. Plug into main power source.
3. No power in incoming line.
 - a. Check outlet.
 - b. Check power cord.
4. Loose wiring
 - a. Check terminals and connections.

MOTOR CREEPS IN STOP POSITION

1. “Min” speed pot on RAMM board out of adjustment.

UNIT TURNS BUT WON'T JOG

1. Jog function was not selected
 - a. Select jog.
2. Jog speed has not been set up
 - a. Call factory.

UNIT ON BUT MOTOR WON'T RUN. (ARMATURE VOLTAGE PRESENT - ON RAMM BOARD)

1. Check motor wiring
 - a. Replace motor cord or correct motor wiring. Call factory.
2. Check motor
 - a. Worn brushes or motor defective. Call factory.
 - b. Check for oil in motor, gear box seal could have ruptured.

UNIT ON BUT MOTOR WON'T RUN. (NO ARMATURE VOLTAGE ON RAMM BOARD)

1. Selector switch not in run position.
 - a. Turn selector switch to run position.
2. If running with a dancer arm control.
 - a. Check that the external/loop arm function is in the loop arm position.
3. If running with external control.
 - a. Check that the external/loop arm function is in the external position.
4. Loop height switch setting too high.
 - a. Set height setting to “0”.
5. Taut stock switch has been tripped.
 - a. Reset the switch on the dancer arm

6. Percent speed function set too low.
 - a. Adjust percent speed function to 100%.
7. Fuses blown.
 - a. Check fuses & circuit breaker.
8. No AC voltage at DC drive board.
 - a. Check wiring.
9. Check Signal voltage between P2 to P1 on DC drive.
0-6 VDC—Ramm
0-9 VDC—Regen Drive
while moving dancer arm.
 - a. If there is a signal, check continuity between I1 & I2.
If no continuity, replace D.C. drive or call factory.
10. Check pico fuse on 69100804 board (F1).
 - a. Replace fuse, 1 amp pico fuse—call factory.

RAPID-AIR CORPORATION

**RAMM
SOLID STATE
DC MOTOR
SPEED CONTROL**

SAFETY WARNING—PLEASE READ CAREFULLY

This product should be installed and serviced by a qualified technician, electrician or electrical maintenance personnel familiar with its operation and the hazards involved. Proper installation (see instruction information which accompanies product), which includes wiring, mounting in proper enclosure, fusing or other over current protection and grounding, can reduce the chance of electrical shocks, fires or explosion in this product or products used with this product, such as electric motors, switches, coils solenoids and/or relays. Eye protection must be worn when working with control under power. This product is constructed of materials (plastics, metals, carbon, silicon, etc.) which may be a potential hazard. Individual material safety data sheets (MSDS) are available upon request. Proper shielding, grounding and filtering of this product can reduce the emission of radio frequency interference (RFI) which may adversely affect sensitive electronic equipment. If information is required on this product, contact our factory. It is the responsibility of the ultimate user of this product to read and comply with this safety warning. (SW effective 1/89)

*****IMPORTANT*****

YOU MUST READ THESE INSTRUCTIONS BEFORE OPERATING CONTROL

1. Be sure AC line voltage corresponds to control voltage.
2. Install the correct Plug-In Horsepower Resistor according to armature voltage and motor horsepower.
3. Recheck connections: AC line to L1 and L2; armature to A+ and A- and field (Shunt motors only to F+ and F-.) (Note: If motor runs in improper direction, interchange armature leads.)
4. Install proper AC line fuse and armature fuse as required.
5. Nominal trim pot settings are as follows (expressed in % of full CW rotation):

TABLE 1: NOMINAL TRIM POT SETTINGS

MIN (minimum speed): 15%	CL (current limit/torque): 65%
MAX (maximum speed): 65%	ACCEL (acceleration start): 20%
IR (IR compensation): 25%	DECEL (deceleration stop): 20%

PLUG IN HORSEPOWER RESISTOR

A Plug-In Horsepower Resistor must be installed to match the RAMM to the motor horsepower and voltage. See table 2 for the correct value. Plug-In Horsepower Resistors are stocked by your distributor.

TABLE 2. PLUG IN HORSEPOWER RESISTOR CHART*

MOTOR HORSEPOWER RANGE **		Plug-in Horsepower Resistor Resistance Value (ohms)	Rapid-Air P/N
Armature Voltage 90-130 VDC	Armature Voltage 180 VDC		
1/4	1/2	.05	69100529
1/2	1	.025	69100530
3/4	1-1/2	.015	69100534
1***	2***	.01	69100531

* Motor horsepower and armature voltage must be specified when ordering so that proper resistor will be supplied.

** For overlapping motor horsepower range use lower value Plug-In Horsepower Resistor.

*** Auxiliary heat sink must be used to achieve HP rating.

INTRODUCTION

The **RAMM** Full Wave Solid State DC Motor Speed Control represents the latest state of the art design achievable through modern technology.

Features Include:

Integrated Circuitry

Used to control and amplify command and reference levels with both closed and open loop feedback to provide superior motor regulation. (Speed changes due to load, line voltage, or temperature variations are held to minimum levels).

High Quality Components

Selected and tested for proven dependability.

Transient Protection

Used to prevent failure of the power bridge circuit caused by voltage spikes on the AC line.

High Reliability

When used in accordance with instructions in this manual, the **RAMM** will provide years of trouble free operation.

A. Initial Setup and Wiring

General Instructions

1. Install proper size Plug-In Horsepower Resistor.
(see table 2)
2. The **RAMM** can be connected to a standard 120V or 240V 50/60 Hz AC line (be sure the AC input voltage corresponds to the control voltage rating and the motor rating). (e.g. 90-130 VDC motor on 120 VAC and 180 VDC motor on 240 VAC)
3. Follow the recommended supply wire sizes as per table 3.
4. Follow the NEC and other electrical codes that apply.

CAUTION: SEPARATE BRANCH PROTECTION MUST BE PROVIDED ON 240V CIRCUITS.

5. Connect control in accordance to connection diagram.

TABLE 3. MINIMUM SUPPLY WIRE SIZE REQUIREMENTS

MAX. MOTOR AMPS (DC AMPS)	MAX. MOTOR HP 90V	MAX. MOTOR HP 180V	MINIMUM WIRE SIZE (AWG) Cu only	
			MAX. MOTOR RUN	MAX. MOTOR RUN
6.0	1/2	1	16	14
12.0	1	2	14	12*
16.0	1 1/2	3	12	12

*Maximum recommended wire size

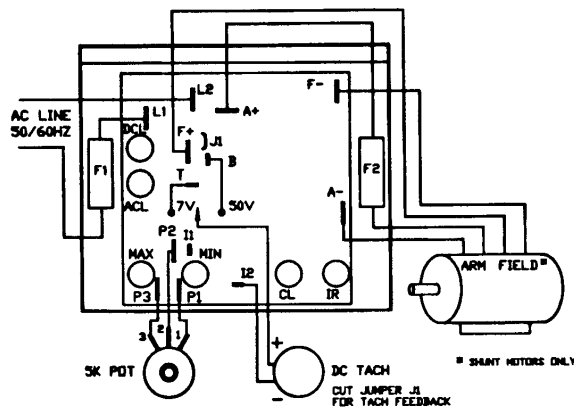

Fig. 1. Basic RAMM Connection Diagram

CAUTION: Do not bundle potentiometer connections (P1, P2, P3) and inhibit connections (I1, I2) with AC line or motor wires.

B. VOLTAGE FOLLOWING. All models can be controlled with an isolated analog reference voltage (0-6 VDC) in lieu of the main speed potentiometer. The voltage is connected to P2 (+) and F-. The control output voltage will linearly follow the input voltage. The source impedance of the input should be 10K ohms or less. The Min trim pot can be used to provide an offset speed. If an offset is not required adjust the Min to 0+ or 0- speed as desired. The Max trim pot is rendered inoperative in the voltage following mode. Use auxiliary trim pot to limit the control range. If the input signal is not isolated, or is a current signal (4-20ma), the RA-SI240D) Signal Isolator must be used. It will allow direct connection to process controllers and microprocessors.

CAUTION: 1. The voltage feeding P2 and F- must be isolated from the AC line. Do not ground P2 or F- to set up a zero ground reference.
2. Do not bundle signal wires to P2 and F- with AC line motor connections. If signal wires are over 18", use shielded cables.

C. FUSING. The RAMM has provision for a built in AC line fuse and armature fuse. The AC line fuse protects the control against catastrophic failure— if the fuse blows, the control is mis-wired, the motor is shorted or grounded, or the RAMM control is defective. The armature fuse provides overload protection for the motor and control. Choose the proper size armature fuse by multiplying the maximum DC motor amps by 1.7. On domestic 240 Volt AC lines, separate branch circuit protection for each line must be used. All fuses should be normal blow ceramic 3AG or ABC or equivalent.

1. AC Line Fuse is chosen according to the maximum rating of the control:
 - 12 AMP fuse for all motors up to 3/4 HP-90 VDC and 1 1/2 HP-180 VDC.
 - 25 AMP fuse for all motors 1 and 1 1/2 HP-90 VDC and 2 and 3 HP-180 VDC.

1. AC Line Fuse is chosen according to the maximum rating of the control:
 12 AMP fuse for all motors up to 3/4 HP-90 VDC and 1 1/2 HP-180 VDC.
 25 AMP fuse for all motors 1 and 1 1/2 HP-90 VDC and 2 and 3 HP-180 VDC.
 (Use Buss ABC, Littlefuse 326 ceramic fuse or equivalent.)
2. Armature Fuse can be chosen in accordance with the fuse chart. Note: The armature fuse is calculated based on the approximate full load DC current rating of the motor times a from factor of 1.5. If motor has characteristics not consistent with these approximations, a different fuse value may have to be used. Fuses are available from your distributor.

TABLE 4. ARMATURE FUSE CHART

90VDC MOTOR	180VDC MOTOR	APPROX. DC MOTOR CURRENT (AMPS)	FUSE RATING (AC AMPS)
HORSEPOWER			
1/4	1/2	2.5	4
1/2	1	5.0	8
3/4	1 1/2	7.5	12*
1	2	10.0	15
1 1/2	3	15.0	25*
*Also used as AC line Fuse.			

ADJUSTMENTS AND CONTROL FUNCTIONS

WARNING: If adjustments are made under power, insulated adjustment tools must be used and eye protection must be worn.

The **RAMM** has been factory adjusted to provide 0-full speed using the speed control knob. Minimum and Maximum speed trim pots are provided to change the speed from other than 0-full speed. The Acceleration (ACCEL) trim pot is provided to allow for a smooth start over an adjustable time period each time the AC power is applied or the speed pot is rotated. The DE-CEL trim pot controls the amount of ramp-down when the speed pot is adjusted to a lower speed. The Current Limit (CL, or torque output) adjustment is factory set to approximately 1 1/2 times the motor rating. The IR Compensation (IR) is factory adjusted to provide excellent motor regulation under normal operation.

NOTE: In order for the IR comp and CL trim pot settings to be correct, the proper Plug-in Horsepower Resistor must be installed for the particular motor and input volt age being used. Do not attempt to change the settings of the trim pots unless absolutely necessary since they are factory adjusted to near optimum settings.

The following procedure, presented in order of adjustment sequence, should be used when readjusting all trim pot functions.

Fig 2. ACCEL/DECEL TRIM POT ADJUSTMENT

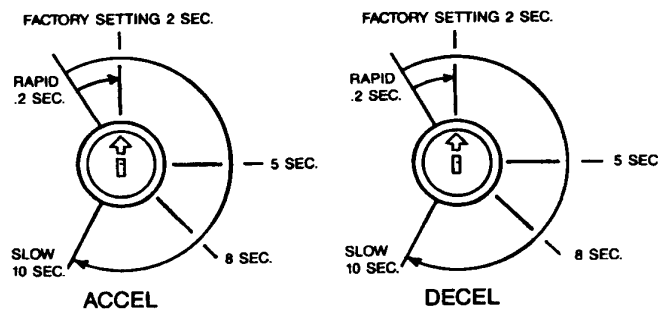

A. Acceleration Start. The ACCEL is factory set at approximately .2 seconds. To readjust to different times, set the knob to the desired position as indicated in Fig 2.

B. Deceleration. The DECEL is factory set to provide a ramp-down time of .2 seconds. To change the ramp-down time, adjust the DECEL trim pot as indicated in Fig 2.

C. Minimum Speed Adjustment. If a higher than zero minimum speed is desired, readjust the minimum speed by turning the speed control knob to zero setting (full CCW position). Then adjust the Min. Speed Trim pot to the desired setting.

NOTE: The min. speed adjustment will affect the max. speed setting. Therefore, it is necessary to readjust the max. speed after the min. speed is adjusted.

D. Maximum Speed Adjustment. Turn Speed Control Knob to full speed (maximum CW position). Adjust max. speed trim pot to new desired setting.

NOTE: Do not attempt to adjust the max. speed above the rated motor RPM since unstable motor operation may occur. For moderate changes in the max. speed, there will be a slight effect on the min. speed setting.

E. Current Limit (CL/Torque Adjustment). CL circuitry is provided to protect the motor and control against overloads. The CL also limits the inrush current to safe level during startup. The CL is factory set to approximately 1.5 times the full load rating of the motor. (CL trim pot is nominally set to approximately 65% of full CW rotation).

To set the CL to factory specifications adjust as follows:

1. Set speed control knob at approximately 30-50% CW rotation.
Set CL trim pot to full CCW position.
2. Connect a DC ammeter in series with the armature lead.
3. Lock shaft of motor (be sure CL pot is in full CCW position).
Apply power and rotate CL pot CW slowly until DC ammeter reads 1.5 times motor rating (do not exceed 2 times motor rating, Max. CW position.)

NOTE: If only an AC ammeter is available, it can be installed in series with the AC line. Follow above instructions; however, set AC amperage at .75 times motor rating.

- F. **IR Compensation Adjustment.** IR compensation is provided to substantially improve load regulation. If the load presented to the motor does not vary substantially, the IR adjustment may be set at a minimum level (approximately 1/4 of full setting). The control is factory adjusted to approximately 3% regulation. If superior performance is desired (less than 1% speed change of base speed from 0 to full load), then the IR comp. Should be adjusted as follows:

NOTES: 1. Excessive IR comp. will cause control to become unstable, which causes motor cogging.
2. For tach feedback applications the IR comp can be set to minimum rotation (full CCW).

1. Set IR comp. trim pot at approximately 25% of CW rotation. Run motor unloaded at approximately 1/3 speed and record RPM.
2. Run motor with maximum load and adjust IR comp. trim pot so that the motor speed under load equals the unloaded speed per step 1.
3. Remove load and recheck unloaded RPM. If unloaded RPM has shifted, repeat procedure for more exact regulation.

The **RAMM** is now compensated to provide minimal speed change under large variations of applied load.

LIMITED WARRANTY—RAMM 125, 225, 225D

For a period of one (1) year from date of original purchase Rapid-Air Corporation will repair or replace without charge devices which our examination proves to be defective in material or workmanship. This warranty is valid if the unit has not been tampered with by unauthorized persons, misused, abused or improperly installed and has been used in accordance with the instructions and/or ratings supplied. The foregoing is in lieu of any other warranty or guarantee expressed or implied, and we are not responsible for any expense (including installation and removal), inconvenience, or consequential damage, including injury to any person, caused by items of our manufacture and/or sale. Some states do not allow certain exclusions or limitations found in this warranty so that they may not apply to you. In any event, Rapid-Air Corporation's total liability, under all circumstances, shall not exceed the full purchase price of this unit.

