



12912 Farnham Avenue White Bear Lake, Minnesota 55110

WILSON WHEEL[®]

OPERATOR'S MANUAL

for

Murata Wiedemann Thick Turret Punch Presses

**Rolling Shear
Rolling Rib
Rolling Offset
Rolling Pincher**

Revised: October 13, 1998

Printed: February 5, 2004

United States
12912 Farnham Avenue
White Bear Lake, MN 55110
Phone: (651) 426-9133
Tel (Free): 800 328-9646
Fax: (651) 426-9134
(Free): 800 222-0002

United Kingdom
Stirling Road, South Marston Ind Estate
Swindon, Wilts SN3 4TQ England
Tel (Free): (0800) 373748
Tel: (01793) 831818
Fax: (01793) 831945 or 46
Toll Free Fax: (0800) 373758

Germany
Ahornweg 3a
D-31867 Lauenau Germany
Tel (Free): 00800-9457668665
Tel: 05043-91000
Fax: 05043-910044
Fax (Free): 00800-945766329

www.wilsontool.com

©2001 Wilson Tool International

INDEX

I. SAFETY WARNING.....	2
II. BASIC TOOLING INFORMATION.....	3
III. TOOL ASSEMBLY / DISASSEMBLY.....	4
IV. INSTALLATION AND OPERATING INSTRUCTIONS.....	6
V. TROUBLESHOOTING	7
<u>BURRS</u>	7
<u>SHEET DISTORTION</u>	7
VI. TOOL MAINTENANCE	8
VII. MACHINE SPECIFICS AND PROGRAMMING EXAMPLES	9

I. SAFETY WARNING

WILSON WHEEL[®] FAMILY OF TOOLING

The Wilson Wheel family of tooling represents a unique and innovative approach to sheet metal fabrication. The operation of this tooling is unlike any other style of tooling manufactured for use in a turret punch press. Therefore, it is imperative that all persons involved in the operation and programming of the turret punch press read and become thoroughly familiar with the entire contents of this manual prior to the installation, use or maintenance of this tooling. Failure to do so may result in operator injury, damage to the turret punch press and/or turret punch press tooling.

For further information about the Wilson Wheel family of tooling, contact your local Wilson Tool Sales Engineer, or our turret tooling Sales Desk.

II. BASIC TOOLING INFORMATION

This section is intended to acquaint you with the uses and limitations of the Wilson Wheel® Family of tooling. Please read all instructions carefully before operating this tool.

A. MATERIAL THICKNESS

1. With the exception of the Rolling Pincher, tools in the Wilson Wheel family of tooling are designed for use with a specific material thickness.
2. The material thickness range for the Wilson Wheel family of tooling is as follows:
 - Minimum material thickness = .030" (.76 mm).
 - Maximum material thickness (Rolling Rib): .098" (2.5 mm)
 - Maximum material thickness (all others):
 - .098" (2.5 mm) in Aluminum
 - .074" (2.0 mm) In Mild Steel
 - .059" (1.5 mm) In Stainless Steel
3. The Rolling Shear tool cannot cut material thicker than what it was ordered for. Both the upper and lower wheel assemblies must be replaced for use on thicker materials. To run thinner material than what the tool was originally designed for, first run the tool in the thinner material and determine if the results are acceptable. If the results are not acceptable, both the upper and lower wheel assemblies must be replaced. (Please follow the instructions provided in **Assembly / Disassembly**, on pages 4 and 5.)
4. The Rolling Rib, and Rolling Offset tools can be used on thicker materials, but the results may not be satisfactory.
5. The Rolling Pincher tool can be used on any of the above listed materials.

B. INTERCHANGEABILITY WITH OTHER TOOLS IN THE WILSON WHEEL FAMILY

Components within the Wilson Wheel family of tooling are not interchangeable. Punch and Die assemblies for the Rolling Shear are matched sets. Do not interchange punch and die assemblies from multiple Rolling Shear tools.

C. SHARPENABILITY

The wheels used in the Wilson Wheel family of tooling are not sharpenable.

D. MACHINE REQUIREMENTS

The Wilson Wheel family of tooling is designed for use in punch presses equipped with a programmable hydraulic ram. An Auto Index station is required for contouring or off axis use.

E. USING THE ROLLING TOOL IN AN ADAPTER

The Wilson Wheel family of tooling may be used in an adapter (i.e. 3-1/2" - 1-1/4" station adapter) without additional limits and/or restrictions placed upon the use of the tool.

F. THE WILSON LUBRICATING SYSTEM (WLS™)

The Wilson Wheel family of tooling is equipped with WLS. This system is designed to provide a constant flow of lubrication to the area between the punch body and the guide, and the area between the guide and the turret bore as well as to the wheel itself. This reservoir should be refilled following every eight hours of operation, or more often in cases of heavy usage.

G. USING THE ROLLING TOOL IN MACHINES WITH A TOOL LUBRICATION SYSTEM (TLS)

Prior to running the Rolling tool in a machine that is equipped with a TLS, it is necessary to prime the oil reservoir in the punch assembly with a small amount of light to medium weight machine oil (see **Installation and Operating Instructions**, page 6).

III. TOOL ASSEMBLY / DISASSEMBLY

A. DIE WHEEL ASSEMBLY

1. Clean the slot and the pocket in the die base. Remove any accumulated grit or debris.
2. Place the wheel assembly into the die base opening. Press down firmly on the wheel assembly until it seats into the bottom of the die base shaft slot.
3. On the Rolling Shear tool, insert the roll pin.
4. Lubricate the wheel assembly and the die base opening liberally with a light to medium weight machine oil. On Rolling Shear tool, make sure that the cutting wheel, and the control wheel turn freely and independently of each other.
5. On the Rolling Shear, and Rolling Pincher, reassemble the die cap. Make sure that the die cap moves up and down freely.
6. Die height should measure 1.20" (30.48 mm) for the Rolling Shear and Rolling Pincher, 1.181" (30.0 mm) for the Rolling Rib, and Rolling Offset.

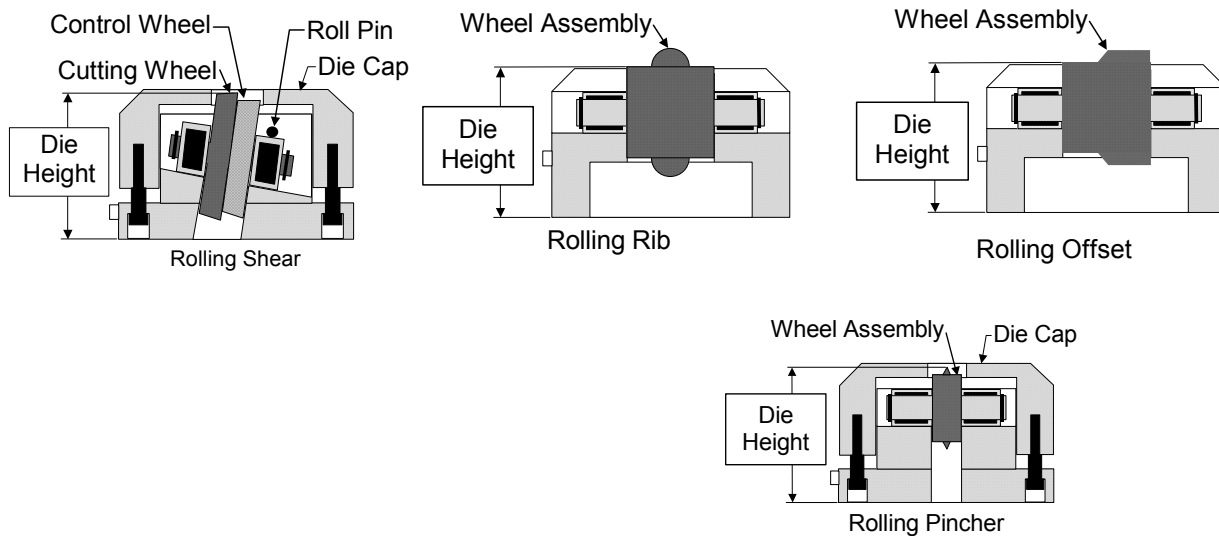

B. DIE WHEEL DISASSEMBLY

1. On the Rolling Shear, and Rolling Pincher, remove the die cap by unscrewing the four M3 cap screws from the bottom of the die base.
CAUTION: The small springs and sleeves will come loose and could easily be lost.
2. On the Rolling Shear, remove the roll pin.
3. On the Rolling Louver, Remove the bearing retainer, by removing the four M3 cap screws from the bottom of the die base.
4. Using a piece of soft brass or aluminum, drive out the wheel assembly. Be careful not to mar the cutting edge.

C. PUNCH WHEEL ASSEMBLY

1. Clean the slot in the punch body. Remove any accumulated grit or debris.
2. Place the wheel assembly into the punch body opening.

NOTE: On the Rolling Shear tool, press down firmly until the wheel assembly seats into the bottom of the punch body shaft slot. Make sure that the wheel assembly is loaded correctly. Wheel flats must be parallel with the punch face.

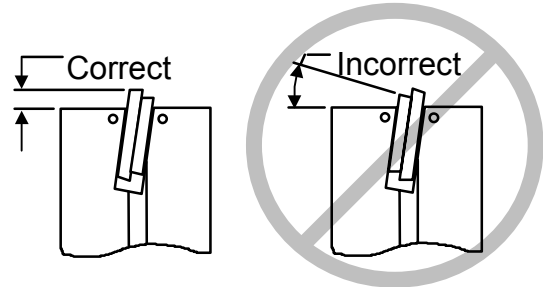

3. Lubricate the wheel assembly and the punch body liberally with a light to medium weight machine oil. On the Rolling Shear tool, make sure that the cutting wheel and the control wheel turn freely and independently.
4. Reassemble the punch cap, or insert the roll pin and tap it into place. Make sure that the roll pin completely engages both sides of the punch face, and is below the surface of the punch, or it may hang up at the end of the turret bore.
5. Adjust the punch length to **8.20" (208.3 mm)**.

D. PUNCH WHEEL DISASSEMBLY

1. Rolling Shear tool
Remove the roll pin from the punch body by tapping it out with a small rod. Secure the punch body firmly. Insert a screwdriver under the punch wheel and pry upward being careful not to mar the cutting edge.
2. Other tools in the Wilson Wheel family of tooling
Remove the four M3 screws from the punch face. Lift off the punch cap, and remove the punch wheel assembly.

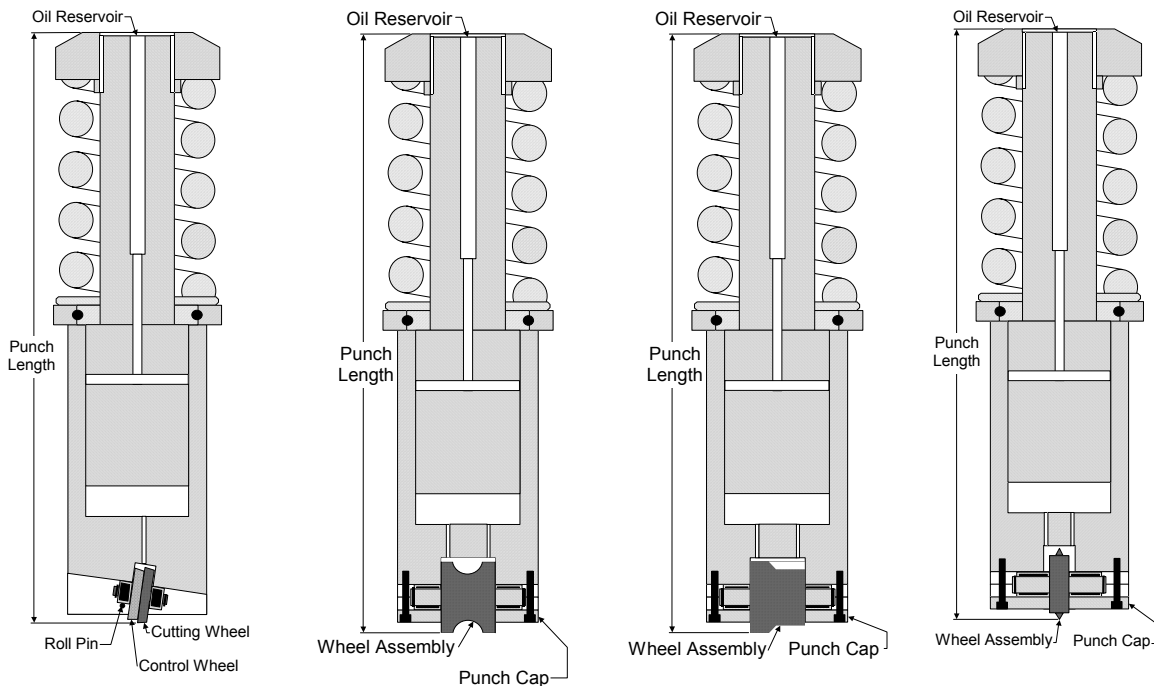

Rolling Shear

Rolling Rib

Rolling Offset

Rolling Pincher

IV. INSTALLATION AND OPERATING INSTRUCTIONS

LOADING THE TOOL INTO YOUR MACHINE

A. MACHINE ALIGNMENT

Good station alignment is imperative when operating the Wilson Wheel family of tooling.

B. CLEANING AND LUBRICATING THE ROLLING TOOL

1. Before operation, **clean and inspect** the tool to make sure it is free from all dirt and shavings. **Do not** use compressed air to clean the tool as this may force debris into the bearings and cause premature wheel failure.
2. On Rolling Shear tool, check to ensure that the cutting wheel, and the control wheel turn freely and independently of each other.
3. Lubricate lower unit by adding light to medium weight machine oil to the top of the wheel assembly while turning the wheels manually.
4. Lubricate the outside of the guide before loading the tool into the machine.
5. After loading the tool into the machine, non-TLS machines should be primed by adding medium weight machine oil into the oil reservoir (the hole in the top of the punch head). Use light machine oil (20-40 weight) for TLS machines.
6. Visually inspect the tool.

NOTE: Repeat Steps 2 through 6 at the beginning of each shift.

LOADING THE SHEET ON THE MACHINE

A. SHEET CLAMPING

If at all possible, you should clamp the sheet along its long side rather than its short side. Make sure the clamps are positioned near the edge of the sheet. When running Stainless Steel, be sure to Use sharp carbide spikes in the clamps.

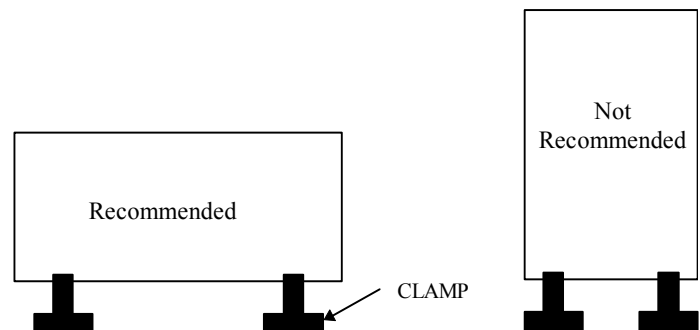

B. SHEET LUBRICATION

The sheet **must** be lubricated if you are running aluminum or hot-dipped galvanized materials. A mixture of equal parts Cutting Oil and Kerosene is recommended. Lubrication should be applied to both sides of the sheet. Lubrication is not mandatory for stainless or mild steel.

When running hot-dipped galvanized steel, you **must** clean the tool frequently. Improper sheet lubrication and/or tool cleaning will result in material buildup and premature tool failure.

V. TROUBLESHOOTING

BURRS

The following chart indicates causes and solutions for excessive burrs (applicable to the Rolling Shear).

CAUSE	SOLUTION
The edge on the tool may be too sharp.	Run a few strips of stainless through until the burr disappears.
The Stroke is set too deep.	Shorten the stroke length in .005" (.13mm) or smaller increments until proper depth is obtained.
The station is improperly aligned.	Align the station
The Auto Index Station is not aligned.	Adjust the angular orientation of the Auto Index Station.
The machine key is worn.	Replace the worn machine key.

SHEET DISTORTION

The following chart indicates causes and solutions for sheet distortion.

CAUSE	SOLUTION
The tool is stroking too deep.	Shorten stroke length by .005" (.13 mm) or smaller increments until proper height is obtained.
Material of .048" (1.22 mm) or thinner is over 20' (508 mm) from the clamps.	Slow your machine speed. Approximately 120' (37 meters) per minute is recommended on straight lines.
You are running toward the clamps.	Run the tool away from the clamps.
The wheel is not turning.	Clean and lubricate the tool (See Installation & Operating Instructions). Inspect the bearings for flat spot
The sheet is moving in the clamps.	Use sharp carbide spikes.
Strips are twisting (Rolling Shear).	Alternate the tool angle from 0° to 180°.

VI. TOOL MAINTENANCE

A. CLEANING AND LUBRICATING

It is important to clean and visually inspect the bearings for flat spots at the beginning of each shift (see **Assembly / Disassembly**, page 4). Likewise, clean and visually inspect the wheels for chips or cracks at the beginning of each shift. Wipe away any accumulated dirt and grit.

After cleaning, lubricate the wheels and bearings with a light to medium weight machine oil or any good quality lubricating oil (see **Assembly / Disassembly**, page 4). You must also lubricate the punch shank body before assembling it into the guide assembly body.

The wheel assembly should be replaced if you notice any chips or cracks in the wheels, or if flat spots occur in the bearings. The Wilson Wheel family of tooling is **not** resharpenable.

VII. MACHINE SPECIFICS and PROGRAMMING EXAMPLES

GENERAL INFORMATION

A. PARAMETERS

All parameters are based on the following:

1. Punch length is 8.20" (208.3 mm). See the figures on page 5.
2. Die height is 1.20" (30.48 mm) for the Rolling Shear and Rolling Pincher, 1.181" (30.0 mm) for the Rolling Rib, and Rolling Offset. See the figures on page 4.

B. STROKE LENGTH ADJUSTMENT

1. The maximum recommended stroke change at any one time is .005" (.13 mm).
2. The tips of the Rolling Pincher tool must never touch. Final stroke adjustment with this tool is critical. Approximately .005" (.1 mm) of material should remain for the best results.
3. Two passes are recommended for the Rolling Pincher. On materials thicker than .048" (1.2 mm) **multiple passes must be used.**

C. OPERATING RESTRICTIONS

1. Standard dead zone restrictions apply with this tool:
2. Minimum distance from the edge of a form is 1.00" (25.4 mm)
3. Minimum radius increases with material thickness, the following values are minimum radii for 18 Ga (.048") [1.2mm] material:

Shear tool	1.75" (45 mm)
Offset tool	1.0" (25 mm)
Rib tool	0.63" (16 mm)
Pincher tool	20.0" (500 mm)

D. TABLE SPEED SPECIFICATIONS

1. Straight lines can be run at full table speed, but Wilson Tool recommends approximately 120' (37 meters) per minute.

E. MULTIPLE PASSES

1. The Rolling Shear should never pass over a cut line more than once.
2. The Rolling Pincher provides better results if two passes are used.
3. Rolling Rib and Rolling Offset tools can take multiple passes if desired.

F. STARTING LOCATION

1. When running the tool in a straight line, always start in the middle of the sheet or at the edge of the sheet. Do not roll through holes. Stop the tool at the edge of the hole, move to the other side and start rolling again.

G. PENETRATION OF MATERIAL

1. When using the Rolling Shear, if you make a cut and it fails to penetrate the material, DO NOT recut in the same place to set the stroke. Adjust the stroke and start again in a new location.

H. ESTABLISHING THE STROKE LENGTH

1. When installing a Wilson Wheel tool in a machine, the combination of stroke length and tool length must be determined. The overall length of the punch should be adjusted to 8.20" (208.3 mm).
2. Always use a straight line to establish the correct stroke length.
3. Stroke length usually varies depending on material thickness. When changing materials, shorten the stroke length on your machine before testing.

PROGRAMMING EXAMPLES (INCHES)

PLEASE NOTE:

The values shown here are approximate. Actual values for your application will vary depending on your machine, your tool, and your material.

1. Punching parameter

On the (**Tool Parameter**) screen:

The tool definition in the tool parameter screen must be defined as a Forming "Special" tool (i.e. **5. F: Forming Tool**, then select **9. Special** type)

Set "**BDC ADJ**" to adjust the stroke. Start with a value of **-.300" (-8.00mm)** and increase the value with small increments after each test run. Always start negative and work your way towards zero. The valid range is from **-.300" to .200"** (-8.00mm to 5.00mm).

2. Sample program to run a straight line (at 0° or 90°).

```
O1111
MAT/B1 H.048 X48 Y48
M321
X0.99 Y26 T01 C90 M03 ←(This offset allows tool to rotate before lowering.)
PDR/X1 Y26 F2000
X45
PED/
M320
C0 (Reset C-axis if another tool isn't used)
X78.74 Y60.039 M30
%
```

3. Sample program to run an arc with 5" radius from 0° to 360°.

```
%
O0007
MAT/B1H.048X48.Y30.;
M80;
M321;
X15.Y14.T17C0.M03;
PDR/X15. Y15. F2000;
CIR/10. 15. 360.;
PED/;
M320;
X78.74Y60.039M30;
%
```